

LIMITED WARRANTY STATEMENT

Rockford Corporation offers a limited warranty on Rockford Fosgate products on the following terms:

Length of Warranty

Speakers – 1 Year-Any Factory Refurbished Product – 90 days (receipt required)

What is Covered

This warranty applies only to Rockford Fosgate products sold to consumers by Authorized Rockford Fosgate Dealers in the United States of America or its possessions. Product purchased by consumers from an Authorized Rockford Fosgate Dealer in another country are covered only by that country's Distributor and not by Rockford Corporation.

Who is Covered

This warranty covers only the original purchaser of Rockford product purchased from an Authorized Rockford Fosgate Dealer in the United States. In order to receive service, the purchaser must provide Rockford with a copy of the receipt stating the customer name, dealer name, product purchased and date of purchase. Products found to be defective during the warranty period will be repaired or replaced (with a product deemed to be equivalent) at Rockford's discretion.

What is Not Covered

1. Damage caused by accident, abuse, improper operations, water, theft, shipping
2. Any cost or expense related to the removal or reinstallation of product
3. Service performed by anyone other than Rockford or an Authorized Rockford Fosgate Service Center
4. Any product which has had the serial number defaced, altered, or removed
5. Subsequent damage to other components
6. Any product purchased outside the U.S.
7. Any product not purchased from an Authorized Rockford Fosgate Dealer

Limit on Implied Warranties

Any implied warranties including warranties of fitness for use and merchantability are limited in duration to the period of the express warranty set forth above. Some states do not allow limitations on the length of an implied warranty, so this limitation may not apply. No person is authorized to assume for Rockford Fosgate any other liability in connection with the sale of the product.

How to Obtain Service

Contact the Authorized Rockford Fosgate Dealer you purchased this product from. If you need further assistance, call 1-800-669-9899 for Rockford Customer Service. You must obtain an **RA# (Return Authorization number)** to return any product to Rockford Fosgate. You are responsible for shipment of product to Rockford.

EU Warranty

This product meets the current EU warranty requirements, see your Authorized dealer for details.



Check our website for additional information and updates on these products.

www.RockfordFosgate.com

© 2011 Rockford Corporation. All rights reserved.

Rockford Fosgate, the Rockford Fosgate logo, and the PUNCH logo are either registered trademarks or trademarks of Rockford Corporation.

Rockford Fosgate®



P | 3

P U N C H™

P3-DVC - DUAL VOICE COIL SUBWOOFERS

	10"	12"	15"
Dual 2-Ohm	P3D2-10	P3D2-12	P3D2-15
Dual 4-Ohm	P3D4-10	P3D4-12	P3D4-15

Installation & Operation

Printed in China

Serial Number: _____ Date of Purchase: _____

SAFETY

CAUTION: Before installation, disconnect the battery negative (-) terminal to prevent damage to the unit, fire and/or possible injury.

PRACTICE SAFE SOUND™

Continuous exposure to sound pressure levels over 100dB may cause permanent hearing loss. High powered auto sound systems may produce sound pressure levels well over 130dB. Use common sense and practice safe sound.

RECOMMENDED ENCLOSURES

This manual outlines two specific types of enclosures that provide distinctly different performance. This section is to help you decide which type is best for your application.

SEALED ENCLOSURES

Sealed enclosures are the simplest to build. The most important part of building a sealed enclosure is to make sure that the enclosure is airtight. Using glue and some type of sealant on all seams will ensure solid construction and prevent air leaks. The box volume will directly impact the performance of the speaker. Larger enclosures will provide flatter response and deeper bass where smaller boxes will provide a bump in the response curve and generally higher output for greater SPL.

Advantages of sealed enclosures:

- Small enclosures
- Linear (Flat) response
- No port noise
- High power handling at all frequencies
- Excellent for sound quality
- Extended low frequency output when compared to vented enclosures

VENTED ENCLOSURES

Vented enclosures vary only from the sealed enclosure in that a vent or port is added to “tune” the enclosure. The enclosures recommended are designed for great overall performance. Larger boxes tend to be easy to tune to lower frequencies while medium and small boxes are easier to tune to higher frequencies. The vented design is less linear in response than the sealed box but with noticeably more output at the tuning frequency.

Advantages of vented enclosures:

- Higher average output than sealed
- Tuning frequency can be easily adjusted by changing port length
- Deep bass response with lower power requirements
- Great for high output with limited power

The graph shown here is a sample of how the F3 drop-off point differs between sealed and vented enclosures.

CARTON CONTENTS

- (1) Punch P3 Series Subwoofer
- (1) Painted aluminum decorative trim ring
- (8) Socket head wood screws
- (1) Socket head driver bit

BUILDING AN ENCLOSURE

To work properly, the walls of the enclosure must be rigid and not flex when subjected to the high pressures generated by the speaker's operation. For optimum performance, we recommend using 3/4" MDF (Medium Density Fiberboard) and internal bracing. The enclosure should be glued together and secured with nails or screws.

CALCULATING VOLUME

Calculating volume is merely a matter of measuring the dimensions in inches and using the formula: H x W x D divided by 1728 (cubic feet). See block below.

Box Volume	Height" x Width" x Depth"
Divided by (cubic feet)	1728

If two facing sides are of uneven length, add them together and divide by two to take the average. Using this number will give you the volume without the necessity of calculating the box in sections and adding the sections together. The thickness of the baffle material reduces the internal volume so this must be subtracted from the outside dimensions to determine the internal volume. The speaker itself also reduces the internal volume. The amount of air displaced by each model is listed on the specification sheet and should also be subtracted from the gross volume calculation.

VENTED VS SEALED

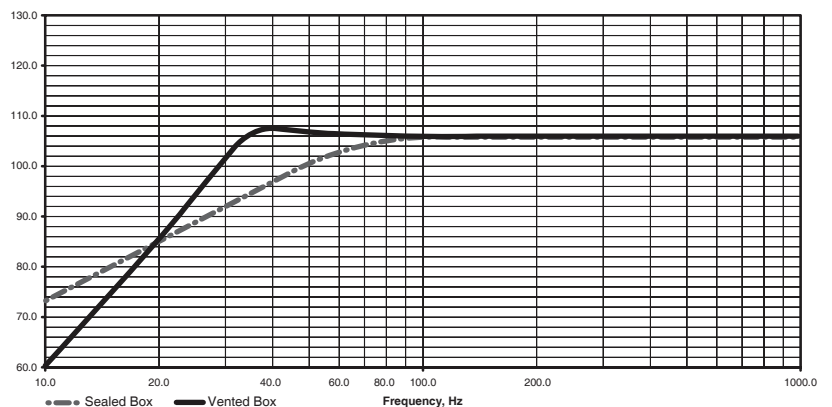

SEALED ENCLOSURES

NOTE: V_b is the gross volume, which is the TOTAL internal volume, before any speaker and/or port displacement.
All external dimensions were based on the use of 3/4" (1.90cm) materials.

NOTE: When using enclosures other than recommended, call Technical Support for correct application.

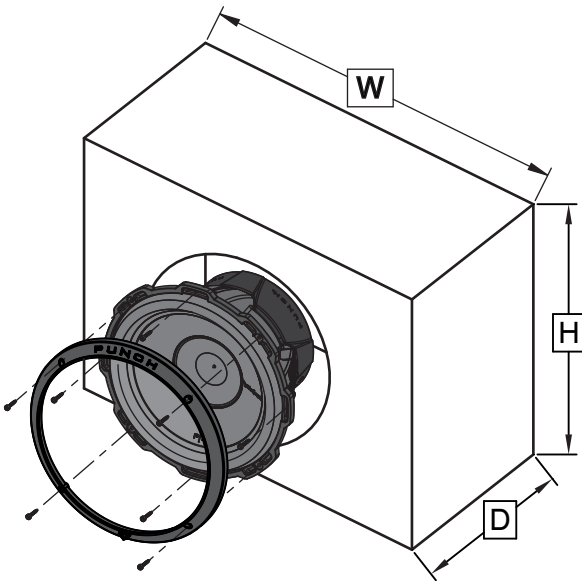

Optimum Sealed Enclosure Recommendation

SEALED ENCLOSURES	10" P3D2-10 / P3D4-10	12" P3D2-12 / P3D4-12	15" P3D2-15 / P3D4-15
V_b - Internal Area cu. ft. (Liter)	0.59 (16.71)	1.02 (28.88)	1.58 (44.74)
F_3 - -3dB Point (Hz)	40.6	42.2	36.2
Qt _c - Enclosure Damping	0.76	0.78	1.01
H - Height-inch (cm)	12.0 (30.48)	14.0 (35.56)	18.0 (45.72)
W - Width-inch (cm)	14.0 (35.56)	18.0 (45.72)	21.0 (53.34)
D - Depth-inch (cm)	9.25 (23.50)	10.0 (25.40)	10.0 (25.40)

Recommended Sealed Enclosure Volume Range

SEALED ENCLOSURES	10" P3D2-10 / P3D4-10	12" P3D2-12 / P3D4-12	15" P3D2-15 / P3D4-15
V_b - Volume Range cu. ft. (Liter)	0.50 to 0.75 (14.16 to 21.24)	0.75 to 1.25 (21.24 to 35.40)	1.50 to 3.00 (42.48 to 84.95)

Specifications subject to change without notice

VENTED ENCLOSURES

NOTE: V_b is the gross volume, which is the TOTAL internal volume, before any speaker and/or port displacement.
All external dimensions were based on the use of 3/4" (1.90cm) materials.

NOTE: When using enclosures other than recommended, call Technical Support for correct application.

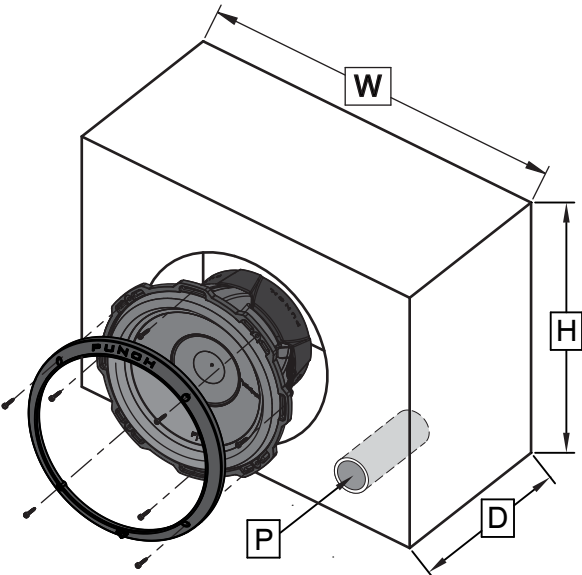

Optimum Vented (Ported) Enclosure Sizes

VENTED ENCLOSURES	10" P3D2-10 / P3D4-10	12" P3D2-12 / P3D4-12	15" P3D2-15 / P3D4-15
V_b - Internal Area cu. ft. (Liter)	1.40 (39.64)	1.79 (50.69)	2.66 (75.32)
F_b - Tuning Frequency (Hz)	40.0	40.0	32.0
F_3 - -3dB Point (Hz)	31.2	32.8	29.8
H - Height-inch (cm)	12.0 (30.48)	14.0 (35.56)	18.0 (45.72)
W - Width-inch (cm)	20.0 (50.80)	25.0 (63.50)	28.0 (71.12)
D - Depth-inch (cm)	14.0 (35.56)	12.0 (30.48)	12.0 (30.48)
P - Port Diameter and Length-inch (cm)	(1) 4 x 14 (1) (10.16 x 35.56)	(1) 4 x 10 (1) (10.16 x 25.40)	(1) 4 x 10 (1) (10.16 x 25.40)

Number of ports noted in ()

Specifications subject to change without notice

NOTE: The port shown can be placed on any face of the enclosure as long as the port ends are not obstructed.

NOTE: When using vented enclosures, for maximum reliability and power handling ensure that a subsonic or "infrasonic" filter is used so that only usable low frequency signal is sent to the subwoofer.

PHYSICAL DIMENSIONS

PUNCH P3-DVC	10" P3D2-10 / P3D4-10	12" P3D2-12 / P3D4-12	15" P3D2-15 / P3D4-15
A - Trim Ring Diameter-inch (cm)	11.26 (28.60)	13.31 (33.80)	16.38 (41.60)
B - Trim Ring Height-inch (cm)	0.89 (2.26)	0.91 (2.30)	0.89 (2.26)
C - Mounting Diameter-inch (cm)	9.125 (23.20)	11.25 (28.50)	13.94 (35.30)
D - Mounting Depth-inch (cm)	6.18 (15.68)	6.66 (16.93)	7.58 (19.25)
E - Overall Diameter-inch (cm)	11.02 (28.00)	13.07 (33.20)	16.14 (41.00)
F - Screw Hole Diameter-inch (cm)	10.16 (25.80)	12.28 (31.20)	14.96 (38.00)
G - Speaker Displacement - cu. ft. (Liter)	0.127 (3.60)	0.194 (5.50)	0.247 (7.00)

Specifications subject to change without notice

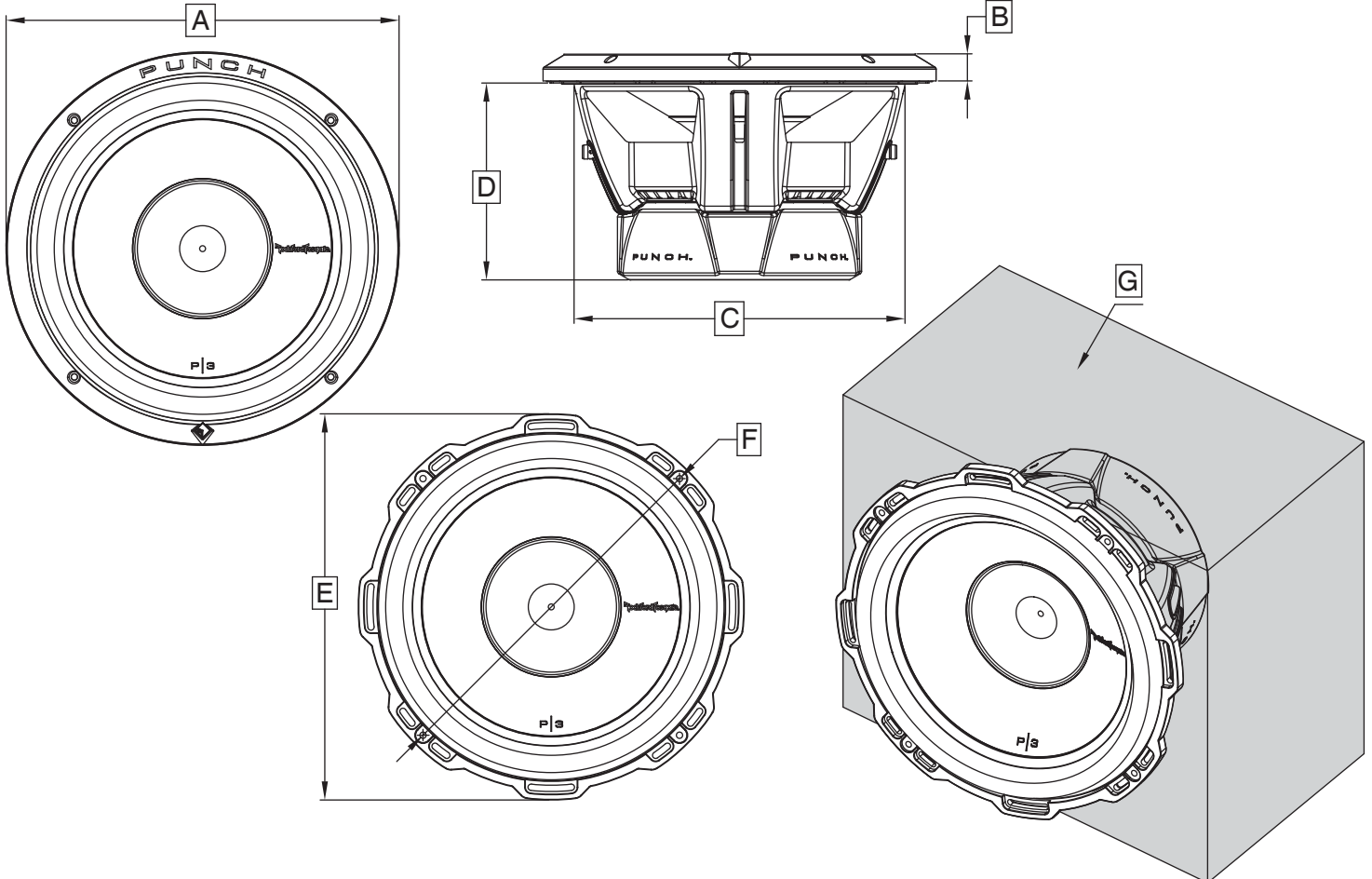

SPECIFICATIONS

PUNCH P3-DVC	10" P3D2-10 / P3D4-10	12" P3D2-12 / P3D4-12	15" P3D2-15 / P3D4-15
Nominal Impedance (ohms)	2 x 2 / 2 x 4	2 x 2 / 2 x 4	2 x 2 / 2 x 4
Frequency Response (Hz)	26.6-250 / 28.0-250	26.5-250 / 27.7-250	21.7-250 / 22.4-250
Voice Coil Diameter - inch (cm)	2.5 (4-Layer) (6.55)	2.5 (4-Layer) (6.55)	2.5 (4-Layer) (6.55)
Displacement - cu. ft. (Liter)	0.074 (2.10)	0.094 (2.66)	0.107 (3.03)
Fs - Free Air Resonance (Hz)	26.6 / 28.0	26.5 / 27.7	21.7 / 22.4
Qts	0.49 / 0.56	0.49 / 0.52	0.54 / 0.57
Vas - cu. ft. (Liter)	0.95 (27.0)	2.04 (57.7)	5.50 (155.8)
Xmax - inch (cm)	0.524 / 0.547 (1.33 / 1.39)	0.524 / 0.547 (1.33 / 1.39)	0.524 / 0.547 (1.33 / 1.39)
SPL (dB @ 1w/1m)	82	85	86
Power Handling-Watts (RMS) (Peak)	500 1000	600 1200	600 1200

Specifications subject to change without notice

WIRING CONFIGURATIONS

By varying the wiring configuration of your speakers you can create an impedance load to match your system. Altering the wiring configurations gives a range of options for impedance loads. Series, Parallel, or Series-Parallel wiring configurations are different techniques for wiring speakers that provide different loads. Series configuration is a string method where speakers are wired end to end. Parallel configuration uses two or more speakers wired across common terminals. Series-Parallel configuration combines both techniques. Choose the wiring diagram that corresponds to the number of woofers and the impedance of your amplifier.

SUBWOOFER CROSSOVERS

There are two operational types of crossovers, passive and active. Passive crossovers (coils or inductors) are placed on the speaker leads between the amplifier and speaker. An active crossover is an electronic filter that separates the audio signal fed to different amplifiers. For optimum subwoofer performance, we recommend using an active 80-100Hz low-pass crossover at 12dB/octave.

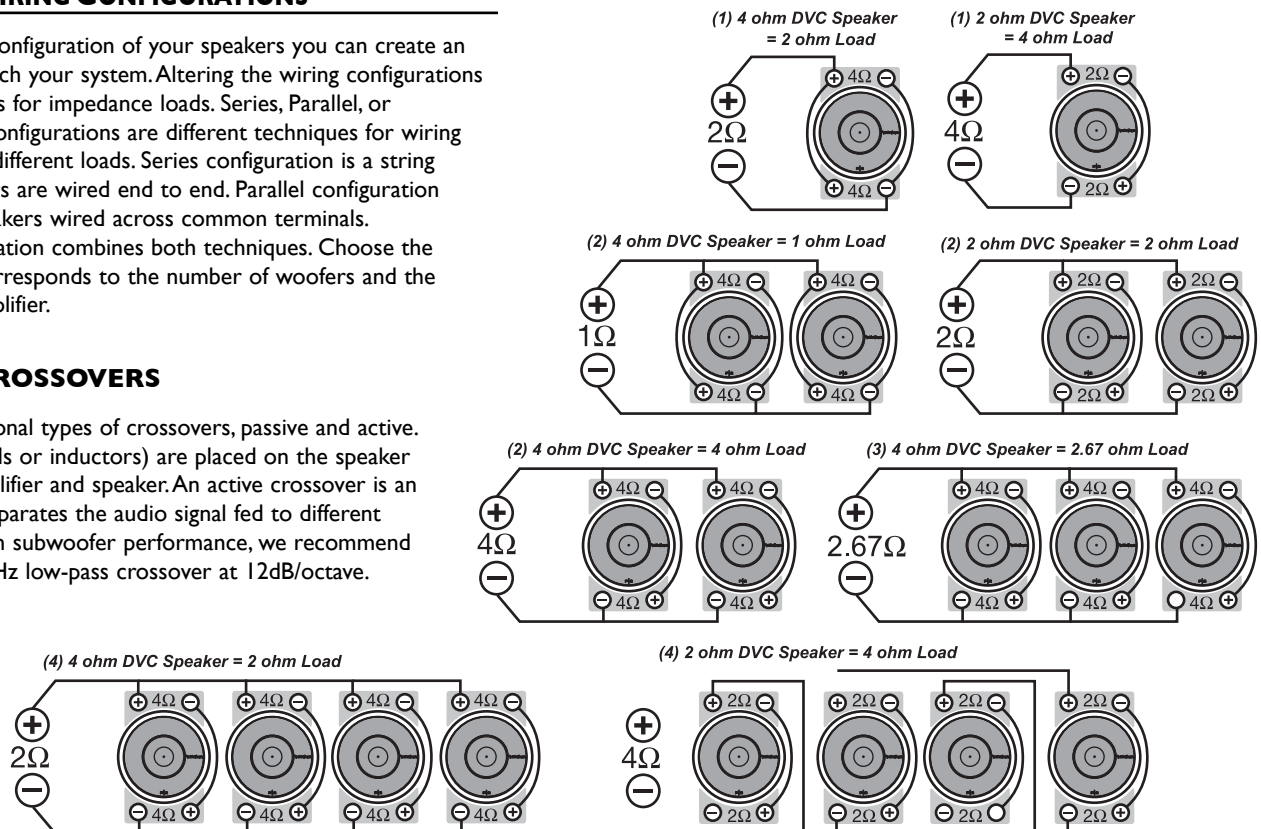

FEATURES

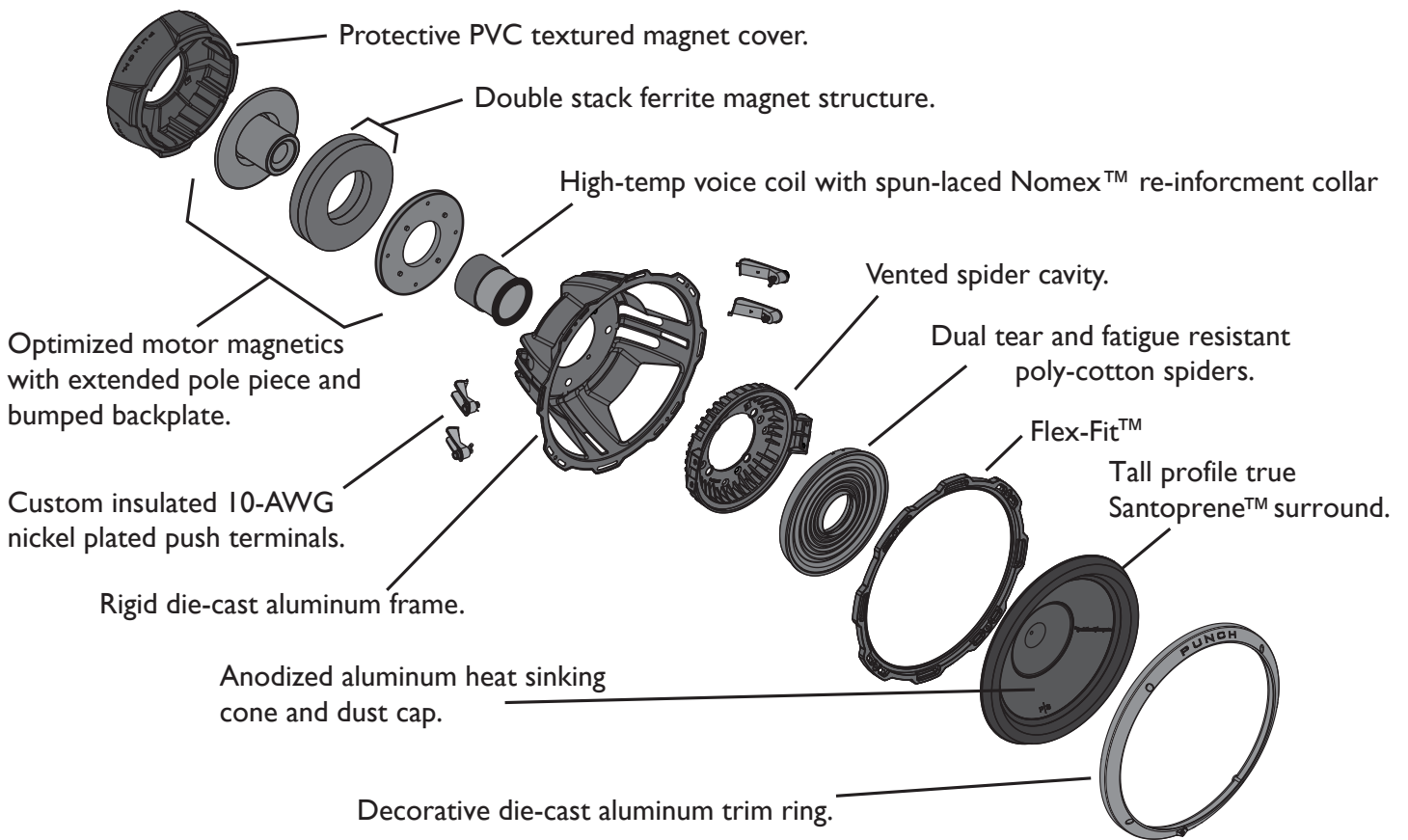

- **Anodized aluminum heat sinking cone and dust cap.**
- **Dual tear & fatigue resistant poly-cotton spiders.**
- **Tall profile true Santoprene™ VAST™ surround.**
- **High temp voice coil with spun-laced Nomex™ insulating reinforcement collar.**
- **Optimized motor magnetics with extended pole and bumped backplate.**
- **Double stack ferrite magnet structure.**
- **Fatigue resistant and reduced strain "stitched on" flexible lead wire design.**
- **Multi-point high-temp/high-strength neck joint bonding technique.**
- **Sturdy 16 gauge compound bend frame geometry.**
- **Semi-flexible PVC removable protective motor cover.**
- **Custom insulated/isolated compression input terminal assembly.**
- **Proprietary spider venting/cooling technique.**
- **Decorative die-cast aluminum trim ring.**